



## FRETOK 105

### fuel protection made simple

The integrated progressive closing float unit prevents fuel transfer from the tank filler neck, which is always the most difficult part to protect.

The installation on the tank is quick, reliable and requires no modifications, sealants or glues.

Compatible with original OEM caps of tanks with 2-point bayonet opening  $\varnothing$  105 mm

#### *recommended applications*

**DAF:** all models - **MAN:** all models - **VOLVO:** all models - **MERCEDES:** all models - **RENAULT:** Premium, Magnum, Midlum with metal tank neck - **IVECO:** Stralis, EuroStar, EuroTec, Trakker, EuroTrakker - **DOOSAN:** all models with metal tank neck - **LIEBHERR:** all models with metal tank neck

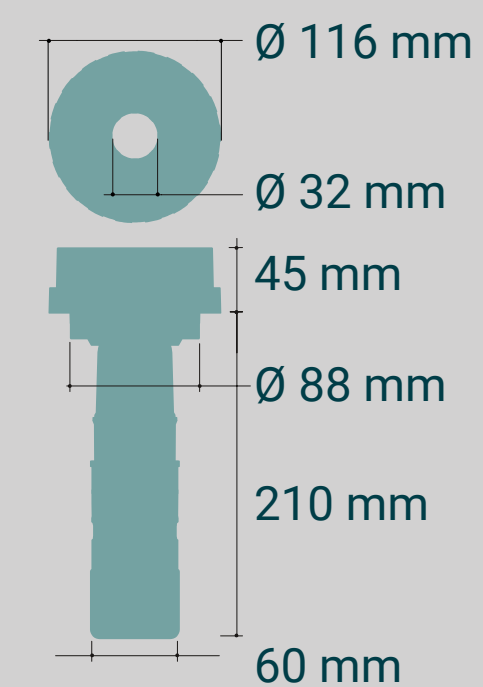

120 l/min



1060 g

2-point internal bayonet fitting 105mm

